

# Proportional Directional Valves Without Feed Back

## K(A)D/TG4V-5, 3\* Series

### Typical Section

KTG4V-5

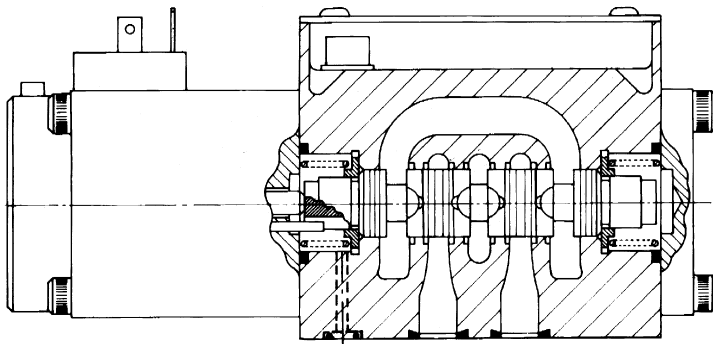

### KAD/TG4V-5 KAD/TG4V-5

A range of proportional directional and throttle valves with control amplifiers built directly on, and prewired to, the valves. Factory-set adjustments of gain, spool deadband compensation, dither and offset ensure high repeatability valve-to-valve.

The only electrical inputs required are power supply (24V) and a voltage command signal of  $\pm 10V$ . Electrical connections are via a standard 7-pin plug.

A monitor point allows the function of the amplifier to be checked. Ramp functions, if required, must be generated externally.

### Features and Benefits

- Factory-sealed adjustments increase valve-to-valve accuracy
- Valve and amplifier selected, ordered, delivered and installed as a performance-tested package
- Standard 24V DC supply with wide tolerance band
- Standard  $\pm 10V$  DC command signals
- Installation wiring reduced and simplified
- Standard 7-pin connector
- LED status indication and monitor point help troubleshooting
- Simple valve removal and replacement for service
- Vibration and shock tested
- Supported by auxiliary function modules

### General Description

Vickers proportional valves shown in this catalog are designed to provide a controlled oil flow in proportion to a command signal. They are available in two types, firstly a double solenoid version that will provide reversible flow and return to an actuator, and secondly a single solenoid version that provides a single direction of flow. Hydrostats are available for load compensation and if flow enhancement is required for the single solenoid version, parallel flow path modules are available that will boost the flow capacity to nearly twice that of the standard valve.

Additionally, both of these valve types can be supplied with or without an integral amplifier built directly onto the valve.

### KD/TG4V-5

This version is supplied without the integral amplifier.

### Features and Benefits

- Wide range of spool and flow rate options
- Supported by amplifiers and auxiliary function modules from the Vickers range
- Electronic feedback LVDT ensures accurate speed control
- Current feedback provides inherent protection from electrical interference
- Vibration and shock tested

**VICKERS**



*This product has been designed and tested to meet specific standards outlined in the European Electromagnetic Compatibility Directive (EMC) 89/336/EEC, amended by 91/263/EEC, 92/31/EEC and 93/68/EEC, article 5. For instructions on installation requirements to achieve effective protection levels, see this leaflet, the Installation Wiring Practices for Vickers Electronic Products leaflet 2468 and leaflet 02-123931A which is packed with every KA valve. Wiring practices relevant to this Directive are indicated by  Electromagnetic Compatibility (EMC).*

# Functional Symbols

## Model Types KADG4V-5

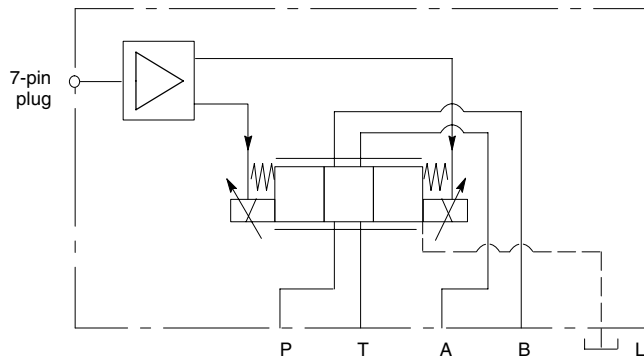

## Available Spools for K(A)DG4V-5

2C\*\*N, meter-in/meter-out

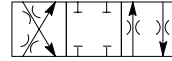

2C65S, meter-out only

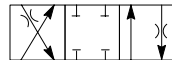

33C\*\*N, meter-in/meter-out

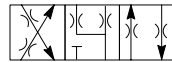

## Model Types KDG4V-5

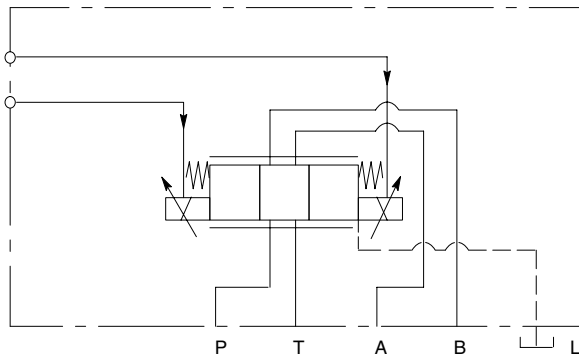

## Available Spools for K(A)TG4V-5

2B\*\*N, meter-in/meter-out

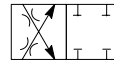

## Model Types KATG4V-5

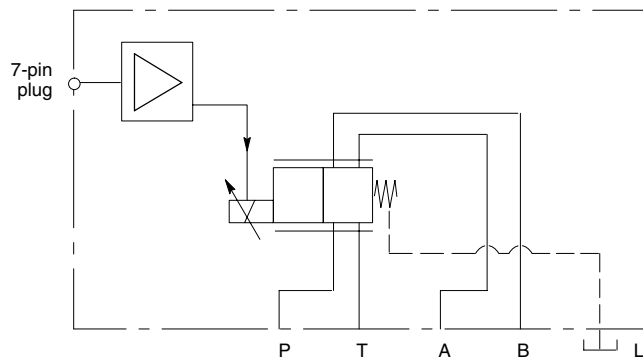

## Model Types KTG4V-5

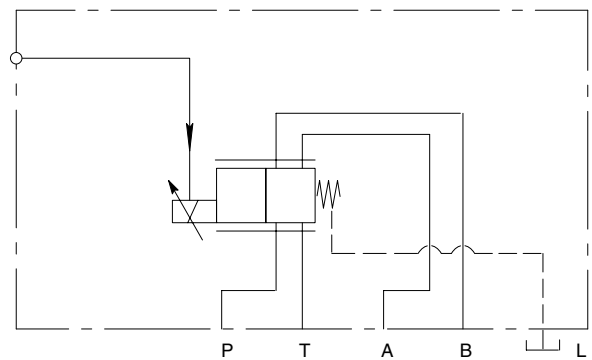

# Model Code

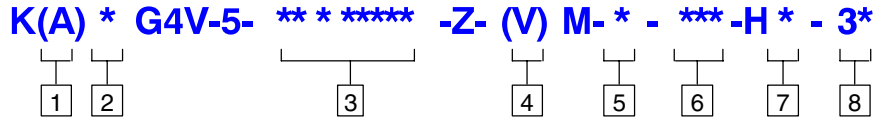

**1 Series type designator**

A = Integral amplifier  
Omit for non-integral amplifier

**2 Control type**

D = Directional valve  
T = Throttle valve

**3 Spool type**

See "Functional Symbols" on previous page

**Flow rating and metering**

$\Delta p = 5$  bar (72 psi) per metering flow path, e.g. B to T

**Spools for K(A)TG valves**

2B30N = 30 L/min (7.9 USgpm)  
2B50N = 50 L/min (13.2 USgpm)  
2B70N = 70 L/min (18.5 USgpm)

**Symmetric spools for K(A)DG valves**

2C30N = 30 L/min (7.9 USgpm)  
2C50N = 50 L/min (13.2 USgpm)  
2C65S = 65 L/min (17.2 USgpm)  
33C30N = 30 L/min (7.9 USgpm)  
33C50N = 50 L/min (13.2 USgpm)

**Asymmetric spools for K(A)DG valves**

2C50N25 = 50 L/min (13.2 USgpm)  
"A" port flow  
25 L/min (6.6 USgpm)  
"B" port flow

**4 Solenoid energization identity**

V = Solenoid "A" is at port "A" end and solenoid "B" at port "B" end, independent of spool type  
Blank = US ANSI B93.9 standard requiring solenoid "A" energization to connect P to A and solenoid "B" to connect P to B

**5 Solenoid electrical connector**

U = ISO 4400/DIN 43650, non-integral amplifier type only  
F = Flying lead, integral amplifier type only

**6 Electrical connection (KA valves only)**

PD7 = 7-pin connector with plastic plug

**See warning note below**

**7 Port T limit code**

6 = For 2C\*\*S spools  
7 = For all other spools

**8 Design number, 30 series**

Subject to change. Installation dimensions unaltered for design numbers 30 to 39 inclusive.

**Solenoid plugs KD/TG4V valves only**

To be ordered separately.  
710775, for black plugs, marked B  
710776, for gray plugs, marked A



**Warning**

To conform to the EC Electromagnetic Compatibility Directive (EMC) the valve with integral amplifiers must be fitted with a metal 7-pin plug. The screen of the cable must be securely connected to the shell of the metal connector. A suitable IP67 rated connector is available from Vickers, part no. 934939. This must be tightened with a torque of 2-2,5 Nm (1.5-2.0 lbf-ft) to achieve the IP67 rating. Alternatively a non IP67 rated connector is available from ITT-Cannon, part no. CA 06 COM-E 14S A7 S.  
The plastic plug, part number 694534, is only suitable for use in a sealed electromagnetic environment or outside of the European Community.

## Operating Data

Performance data is typical with fluid at 36 cSt (168 SUS) and 50°C (122°F) while using the basic Vickers power amplifier.

### KD/TG4V-5 and KAD/TG4V-5 Valves

Relative duty factor	Continuous rating (ED = 100%)
Type of protection, with electrical plugs fitted correctly	IEC 144, Class IP65
Hysteresis, with flow through P-A-B-T, $\Delta p = 5$ bar (72 psi) per metering path e.g. P-A	<8% of rated flow
Step input response, with flow through P-A-B-T, $\Delta p = 5$ bar (72 psi) per metering path e.g. P-A Required flow step: 0 to 100% 100% to 0 +90 to -90% (KADG4V-5 only)	Time to reach 90% of required step: 75 ms (0.075s) 50 ms (0.050s) 80 ms (0.080s)
Mass:	
KDG4V-5	6,8 kg (15.00 lb) approx.
KADG4V-5	7,2 kg (15.90 lb) approx.
KTG4V-5	5,3 kg (11.70 lb) approx.
KATG4V-5	5,7 kg (12.60 lb) approx.

### KD/TG4V-5 Valves

Max. current, at 50°C (122°F) ambient:	
Coil type G	3,5A
Coil type GP	3,0A
Coil type H	1,6A
Coil type HA	0,94A
Coil resistance, at 20°C (68°F):	
Coil type G	1,68Ω
Coil type GP	–
Coil type H	7,7Ω
Coil type HA	23,5Ω
Coil inductance at 1000 Hz & 150 mV:	
Coil type G	8 mH
Coil type GP	–
Coil type H	38 mH
Coil type HA	114 mH
Repeatability, valve-to-valve	Optimized by adjustment of deadband, gain and ramp potentiometers on associated Vickers amplifier
Supporting products:	
Eurocard amplifier	EEA-PAM-525-* -32
Power supply	EEA-PSU-704-* -20

### KAD/TG4V-5 Valves with Integral Amplifiers

Power supply	24V DC (21V to 36V including 10% peak-to-peak max. ripple) max. current 3A														
Command signal Input impedance	0 to +10V DC, or 0 to -10V DC, or -10V to +10V DC 47 kΩ														
7-pin plug connector Pin connections:	<table style="border: none;"> <tr><td style="padding-right: 20px;">A</td><td>Power supply +ve</td></tr> <tr><td>B</td><td>Power 0V</td></tr> <tr><td>C</td><td>Signal 0V</td></tr> <tr><td>D</td><td>+ve voltage command signal</td></tr> <tr><td>E</td><td>-ve voltage command signal</td></tr> <tr><td>F</td><td>Monitor output</td></tr> <tr><td>G</td><td>Protective ground</td></tr> </table>	A	Power supply +ve	B	Power 0V	C	Signal 0V	D	+ve voltage command signal	E	-ve voltage command signal	F	Monitor output	G	Protective ground
A	Power supply +ve														
B	Power 0V														
C	Signal 0V														
D	+ve voltage command signal														
E	-ve voltage command signal														
F	Monitor output														
G	Protective ground														
Electro-magnetic compatibility (EMC): Emission (10 v/m) Immunity (10 v/m) See "Warning" note regarding EMC on page 11.	EN 50081-2 EN 50082-2														
Gain adjustment	25 to 125%														
Zero adjustment	± 18%														
Factory set adjustments	Deadband, gain, dither and offset														
Monitor point signal Output impedance	0,5V per amp solenoid current 10 kΩ														
Power stage PWM frequency	2 kHz nominal														
Repeatability, valve-to-valve (at factory settings): Flow gain at 100% command signal	≤ 5%														
Protection: Electrical Mechanical	Reverse polarity protected IEC 144, Class IP65														
Relative humidity	85 to 95% at 20 to 70°C (68 to 158°F)														
Supporting products: Auxiliary electronic modules (DIN-rail mounting): EHA-CON-201-A-2* signal converter EHD-DSG-201-A-1* command signal generator EHA-RMP-201-A-2* ramp generator EHA-PID-201-A-2* PID controller Subplates, size 05 Mounting bolts Note: If not using Vickers recommended bolt kits, bolts must be to ISO 898 grade 12.9 or stronger.															



*This product has been designed and tested to meet specific standards outlined in the European Electromagnetic Compatibility Directive (EMC) 89/336/EEC, amended by 91/263/EEC, 92/31/EEC and 93/68/EEC, article 5. For instructions on installation requirements to achieve effective protection levels, see this leaflet and the Installation Wiring Practices for Vickers Electronic Products leaflet 2468 and leaflet 02-123931A which is packed with every KA valve.. Wiring practices relevant to this Directive are indicated by  Electromagnetic Compatibility (EMC).*

# Maximum Pressures, bar (psi)

Model	Port L condition s	Ports P, A & B	T	Ls
K(A)DG4V-5- <b>**C**N</b> -Z-(V)M-U1-HZ	Externally drained	315 (4567)	210 (3000)	10 (145)
All K(A)DG4V-5 models	Blocked by mating surface	315 (4567)	160 (2320)	160 (2320)
K(A)TG4V-5	Externally drained	315 (4567)	210 (3000)	10 (145)
	Blocked by mating surface		160 (2320)	160 (2320)

s If port T pressure will not exceed 160 bar (2320 psi), port L need not be connected to tank.

# Minimum Recommended Flow Rates

For spool types 2C and 33C  
 $\Delta p = 10 \text{ bar (145 psi)}$  for looped flow  
 P-A-B-T (or P-B-A-T).

Valve size/spool code	Min. flow rate:	
	L/min	in <sup>3</sup> /min
K(A)DG4V-5- <b>**C30N</b>	1,5	91
K(A)DG4V-5- <b>**C50N</b>	2,5	152
K(A)DG4V-5- <b>**C65S</b>	3,0	182

# Power Capacity Envelopes

Single Solenoid Models:

**K(A)TG4V-5**

Spool types as noted

**Single Flow Path**

P to B



**Looped Flow Path**

P to B plus A to T

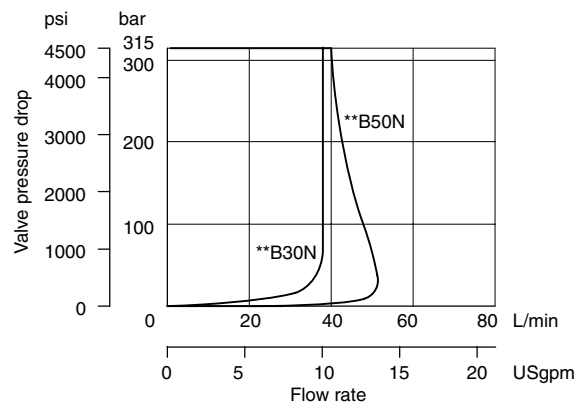
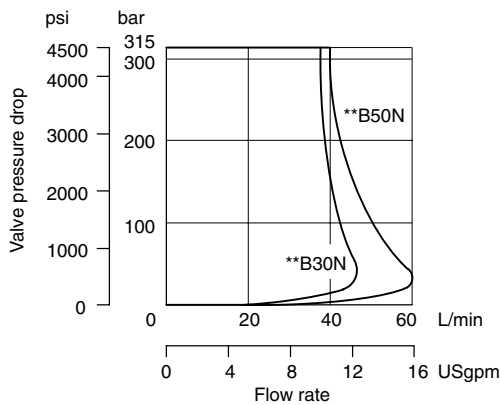

**Single Solenoid Models:  
K(A)TG4V-5**

**Parallel Flow Path**  
P to B and A to T using  
parallel flow path module:  
KDGMA-5-616877-10Rn or  
KDGMA-5-02-139150-10Sn

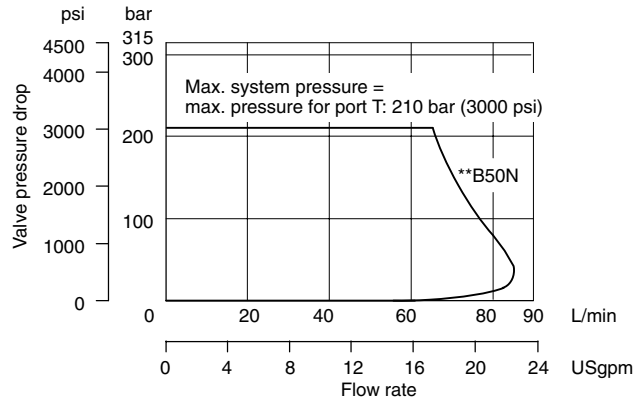
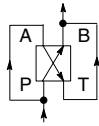

<sup>n</sup> See catalog 2336, "Subplates and Auxiliary Connection Plates, Size 05".

**Double Solenoid Models:  
K(A)DG4V-5**

Spool types as noted

**Single Flow Path**  
P to A, or P to B

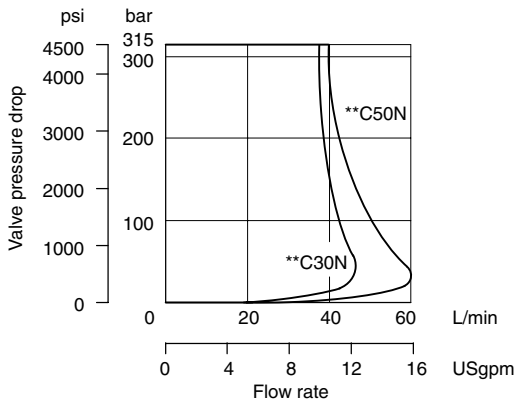
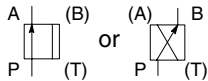

**Looped Flow Path**  
P to A (or B) plus B (or A) to T

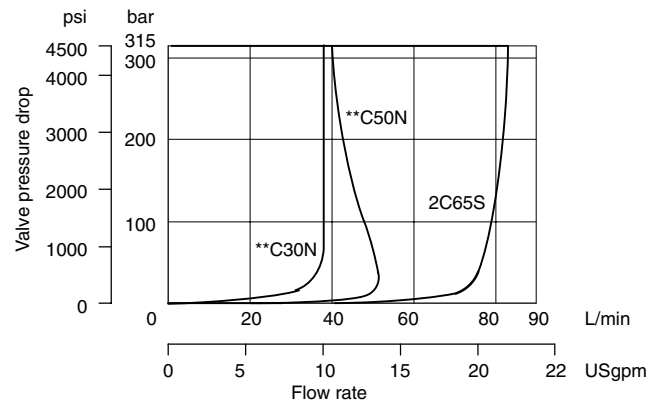
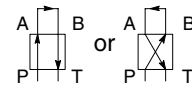

**Frequency Response**

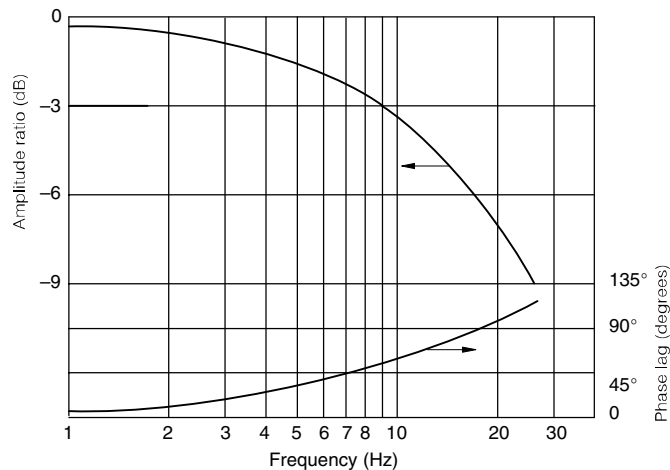

# Flow Gain

## Single Solenoid Models, K(A)TG4V-5

### Single Flow Path

P to B

Spool types \*\*B30N

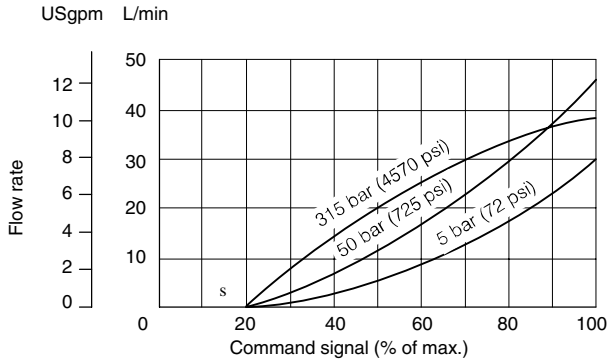

Spool types \*\*B50N

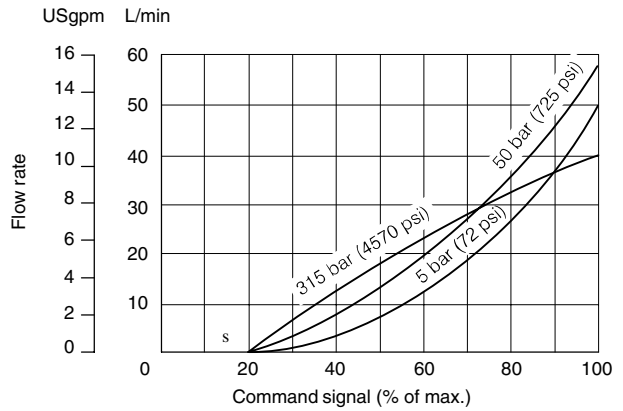

### Parallel Flow Paths

P to B and A to T using parallel flow path module:

KDGMMA-5-616877-10Rn or  
KDGMMA-5-02-139150-10Sn

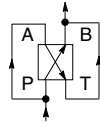

Maximum system pressures for this configuration:

With "L" port externally drained . . . . 210 bar (3000 psi)

With "L" port blocked . . . . . 160 bar (2320 psi)

Spool types \*\*B50N

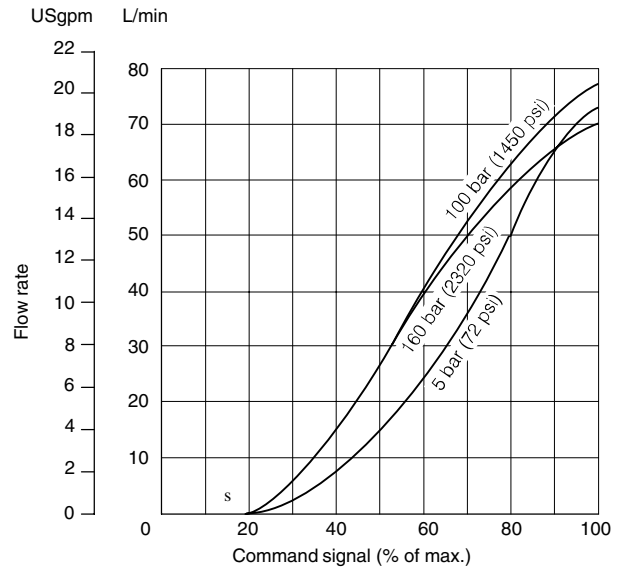

s Curves shown are for spool types "2". These points will vary from valve to valve, but can be adjusted using the deadband compensation feature of the drive amplifier.

For spool types "33" the curves are similar but flow starts at slightly higher command signals.



# Flow Gain

## Double Solenoid Models, K(A)DG4V-5

### Single Flow Path

P to A, or P to B

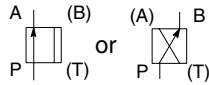

### Spool types \*\*C30N

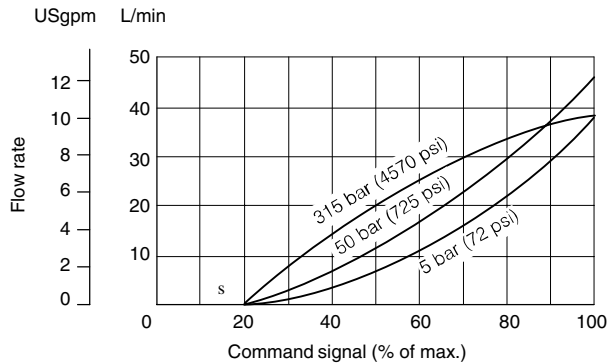

### Spool types \*\*C50N

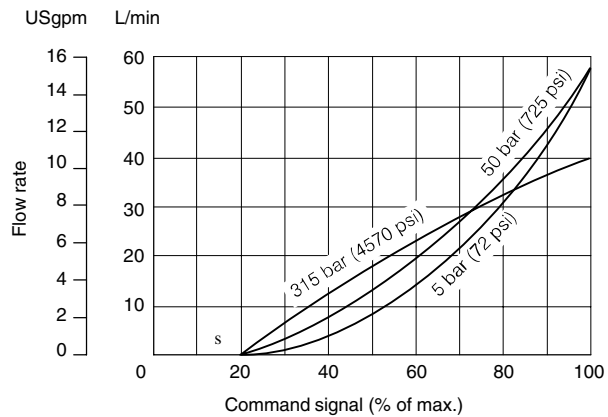

### Spool type 2C65S

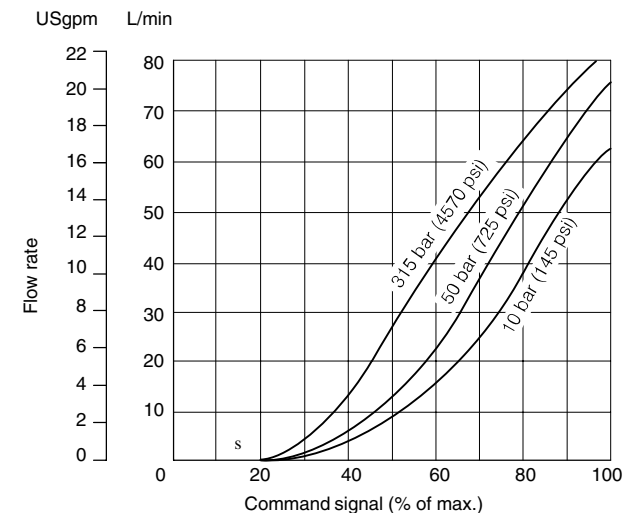

### Looped Flow Paths

P to A (or B), plus B (or A) to T

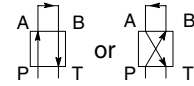

### Spool types \*\*C30N

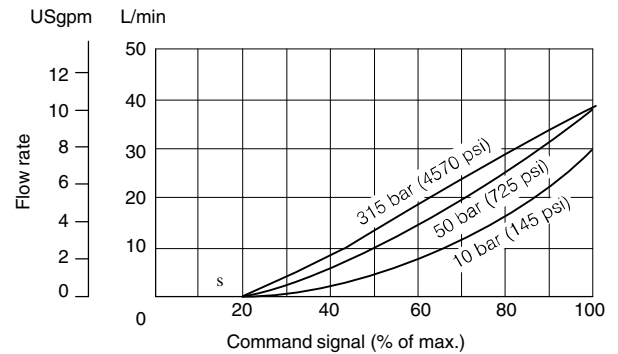

### Spool types \*\*C50N

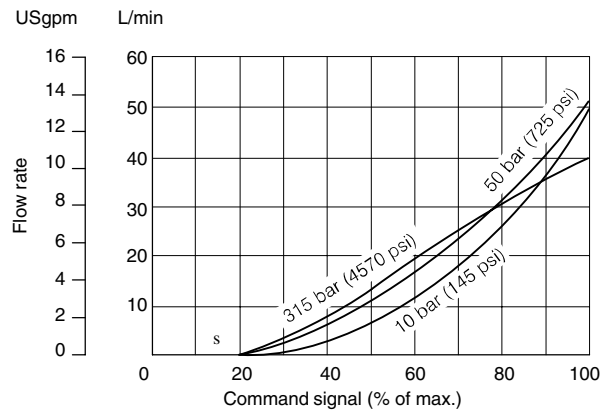

s Curves shown are for spool types "2". These points will vary from valve to valve, but can be adjusted using the deadband compensation feature of the drive amplifier.  
 For spool types "33" the curves are similar but flow starts at slightly higher command signals.

# Electrical Block Diagram

## Command Signals and Outputs

7-pin plug		Flow direction
Pin D	Pin E	
Positive	0V	P to A
0V	Negative	
$U_D - U_E = \text{Positive}$		P to B
Negative	0V	
0V	Positive	
$U_D - U_E = \text{Negative}$		

## KADG4V-5 and KATG4V-5

### Wiring

Connections must be made via the 7-pin plug mounted on the amplifier.  
Recommended cable sizes are:

Power cables:

For 24V supply

0,75 mm<sup>2</sup> (18 AWG) up to 20m (65 ft)

1,00 mm<sup>2</sup> (17 AWG) up to 40m (130 ft)

Signal cables:

0,50 mm<sup>2</sup> (20 AWG)

Screen:

A suitable cable would have 7 cores, a separate screen for the signal wires and an overall screen.

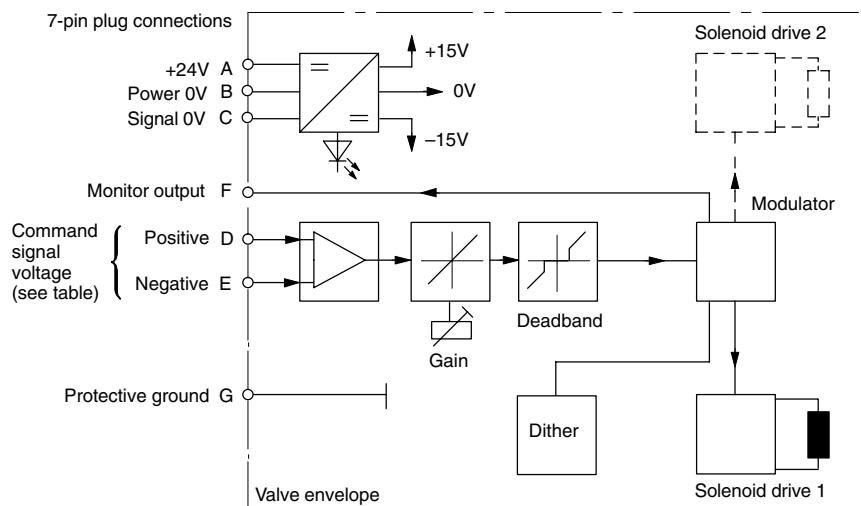

### Warning

All power must be switched off before connecting or disconnecting any plugs.

# Typical Connection Arrangements KADG4V-5 and KATG4V-5

## Wiring Connections for Valves with integral Amplifier

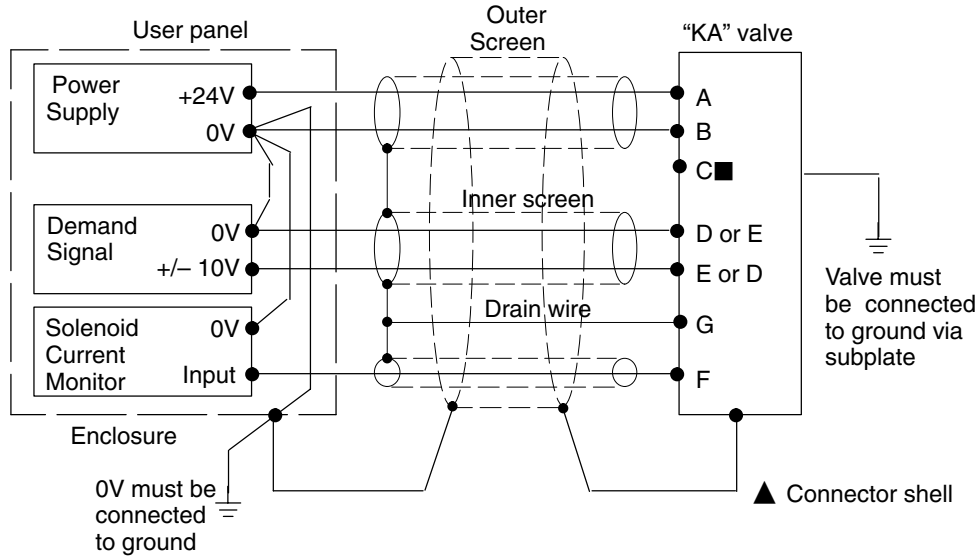

■ Solenoid current monitor voltage (pin F) will be referenced to the KA valve local ground. A “local ground” (pin C) is provided for optional use by differential input customer supplied electronics.

▲ Note: In applications where the valve must conform to European RFI/EMC regulations, the outer screen (shield) must be connected to the outer shell of the 7-pin connector and the valve body must be fastened to the earth ground. Proper earth grounding practices must be observed in this case, as any differences in command source and valve ground potentials will result in a screen (shield) ground loop.



### Warning

Do not ground pin C. If the local ground (pin C) is not used for differential monitor electronics, do not use. Read monitor pin F with respect to ground.



### Warning

Electromagnetic Compatibility (EMC)

It is necessary to ensure that the valve is wired-up as above. For effective protection, the user electrical cabinet, the valve subplate or manifold, and the cable screens should be connected to efficient ground points. The metal 7-point connector, part no. 934939, should be used for the integral amplifier.

In all cases, both valve and cable should be kept as far as possible from any sources of electromagnetic radiation such as cables carrying heavy current, relays and certain kinds of portable radio transmitters, etc. Difficult environments could mean that extra screening may be necessary to avoid the interference.

It is important to connect the 0V lines as shown above. The multi-core cable should have at least two screens to separate the demand signal and monitor output from the power lines.

# Installation Dimensions in mm (in)

## KDG4V-5

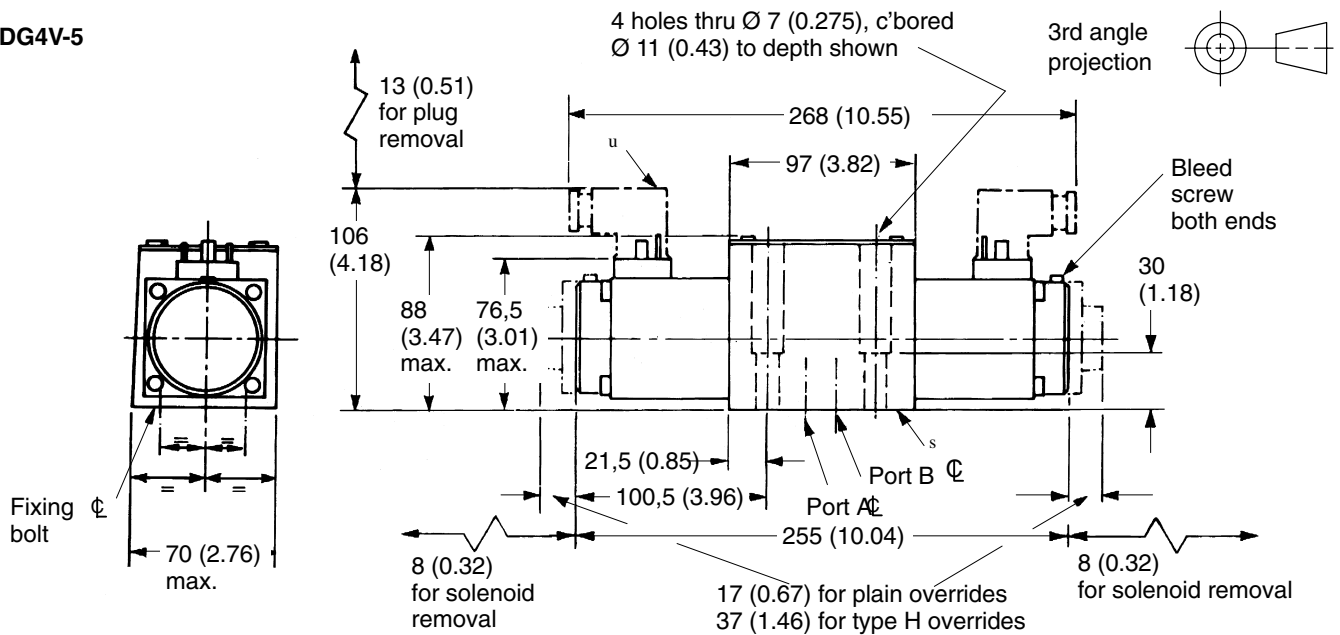

u Electrical plug connections (without indicator light) to ISO 4400/DIN 43650. Must be separately ordered by part number(s).

Part No	Color	Solenoid coil	Cable gland
710775	Black	Solenoid B	Pg. 11
710776	Gray	Solenoid A	Ø 6-10 (0.23-0.39 dia)

Solenoid and plug identities

At port "A" end	At port "B" end	For
A	B	KDG4V-5-*C***(-*)-VM
B	A	KDG4V-5-*C***(-*)-M

The cable entry can be repositioned at 90° intervals from the position shown. This is done by re-assembling the contact holder into the appropriate position inside the plug connector housing.

## KTG4V-5

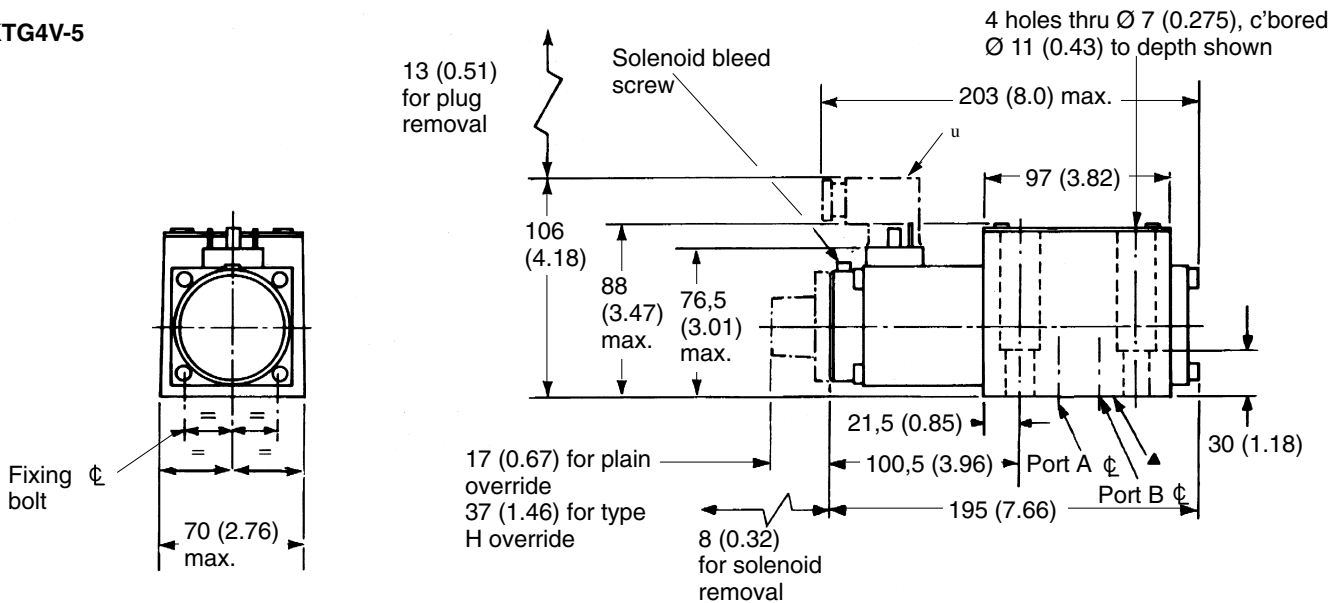

u Electrical plug connections (without indicator light) to ISO 4400/DIN 43650. Must be separately ordered by part number(s).

Part No	Color	Solenoid coil	Cable gland	For valve
710775	Black	Solenoid B	Pg. 11	KTG4V-5-*B***(-*)-M
710776	Gray	Solenoid A	Ø 6-10 (0.23-0.39 dia)	KTG4V-5-*B***(-*)-VM

The cable entry can be repositioned at 90° intervals from the position shown. This is done by re-assembling the contact holder into the appropriate position inside the plug connector housing.

s Mounting surface, seals supplied.

For mating surface dimensions and subplate options, see catalog 2336. For mounting bolt kit options see catalog 2314.

# Installation Dimensions in mm (in)

## KADG4V-5

### Metal plug 934939

Cable outside diameter 8,0 to 10,5 (0.31 to 0.41) Must be used for full EMC protection. See "Warning" note on page 11.

### Plastic plug 694534

PG11. Cable maximum outside diameter 11,0 (0.43)

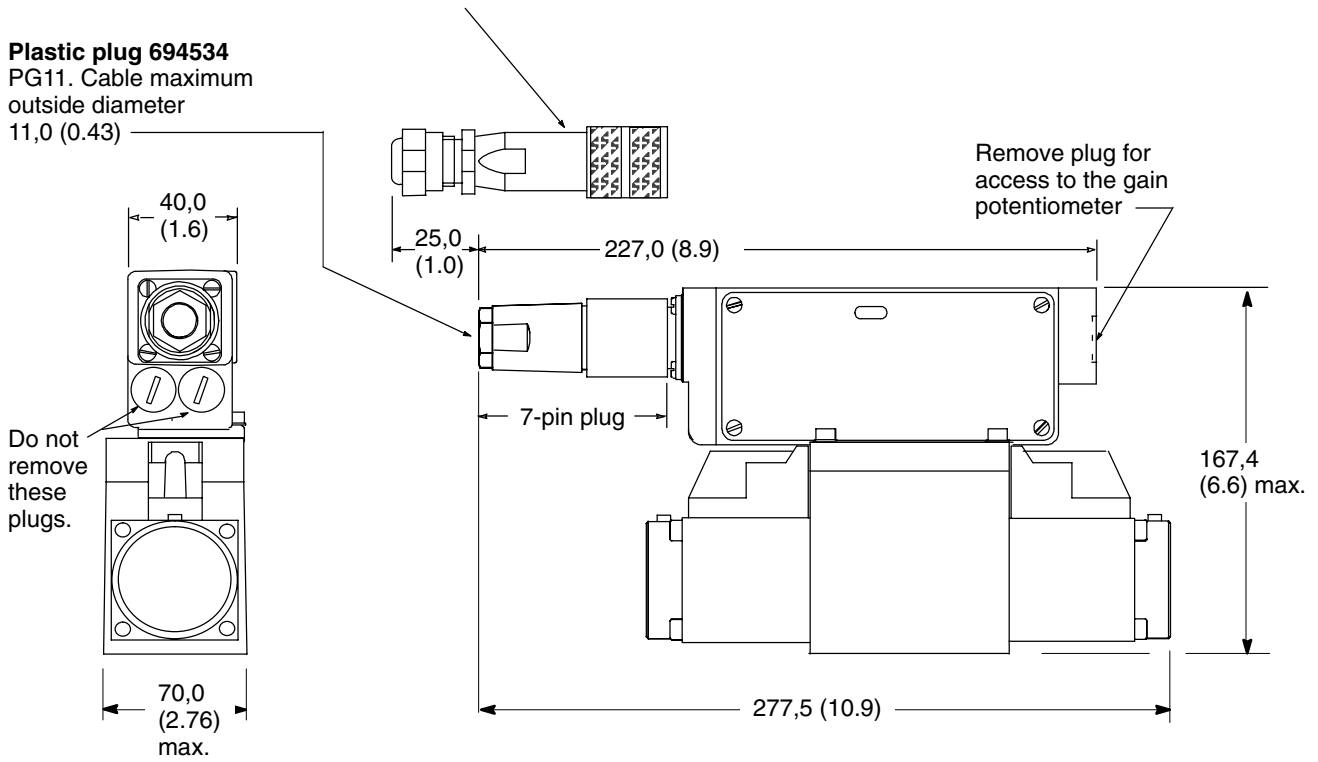

See warning note on page 3 regarding the use of 7-pin plugs.

## KATG4V-5

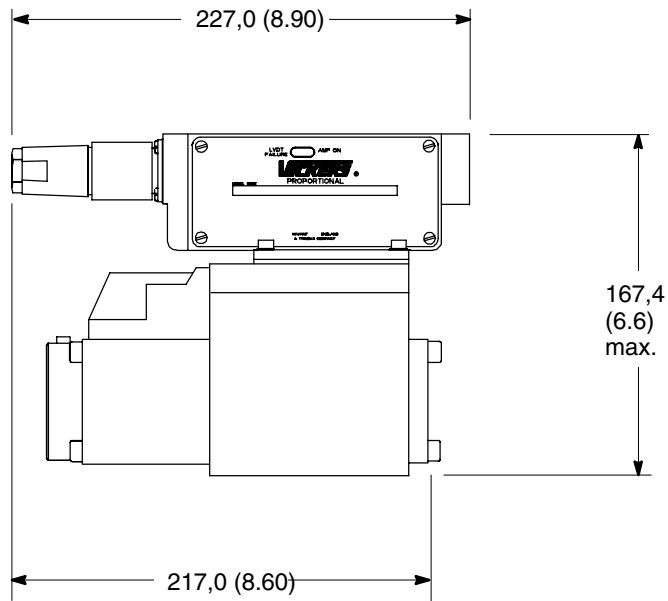

## Further Information

### Hydraulic Fluids

Materials and seals used in these valves are compatible with:

Anti-wear petroleum oils . . . . . L-HM

Non-alkyl based

phosphate esters . . . . . L-HFD

The extreme operating range is 500 to 13 cSt (270 to 70 SUS) but the recommended running range is 54 to 13 cSt (245 to 70 SUS). For further technical information about fluids see Technical Information leaflet B-920 or I-286-S.

### Contamination Control Requirements

Recommendations on contamination control methods and the selection of products to control fluid condition are included in Vickers publication 9132 or 561, "Vickers Guide to Systemic Contamination Control". The book also includes information on the Vickers concept of "ProActive Maintenance". The following recommendations are based on ISO cleanliness levels at 2 µm, 5 µm and 15 µm.

For products in this catalog the recommended levels are:

Up to 210 bar (3050 bar) . . . . . 18/16/13

Above 210 bar (3050 bar) . . . . . 17/15/12

### Installation and Start-up Guidelines

The proportional valves in this catalog can be mounted in any attitude but it may be necessary, in certain demanding applications, to ensure that the solenoids are kept full of hydraulic fluid. If this proves to be the case any accumulated air can be bled from the solenoid bleed screws. This task is easier if the valve has been mounted base downwards. Good installation practice dictates that the tank port, and any drain port, are piped so as to keep the valve full of fluid once the system start-up has been completed.

### Temperatures

For petroleum oil:

Min. . . . . -20°C (-4°F)

Max.\* . . . . . +70°C (158°F)

\* To obtain optimum service life from both fluid and hydraulic system, 65° C (150° F) normally is the maximum temperature.

For other fluids where limits are outside those of petroleum oil, consult fluid manufacturer or Vickers representative. Whatever the actual temperature range, ensure that viscosities stay within those specified under "Hydraulic Fluids".

Ambient for:

Valves, including any feedback transducers and integral amplifiers at full performance specification: -20 to +60°C (-4 to +140°F).

Valves, as above, will operate at temperatures of 0 to -20°C (32 to -4°F) but with a reduced dynamic response.

Storage:

-25 to +85°C (-13 to +185°F)

Eurocard electronics:

0 to 50°C (32 to 122°F)

### Service Information

The products from this range are preset at the factory for optimum performance, disassembling critical items would destroy those settings. It is therefore recommended that should any mechanical or electronic repair be necessary they should be returned to the nearest Vickers repair center. The products will be refurbished as necessary and retested to specification before return to you.

Field repair is restricted to the replacement of the listed parts below.

Seal kit (KD/TG) . . . . . 565110

Seal kit (KAD/TG) . . . . . 02-139127